

REVISIONS				
ZONE	REV.	DESCRIPTION	DATE	APPD.

1
2
3
4
5
6
7
8
9

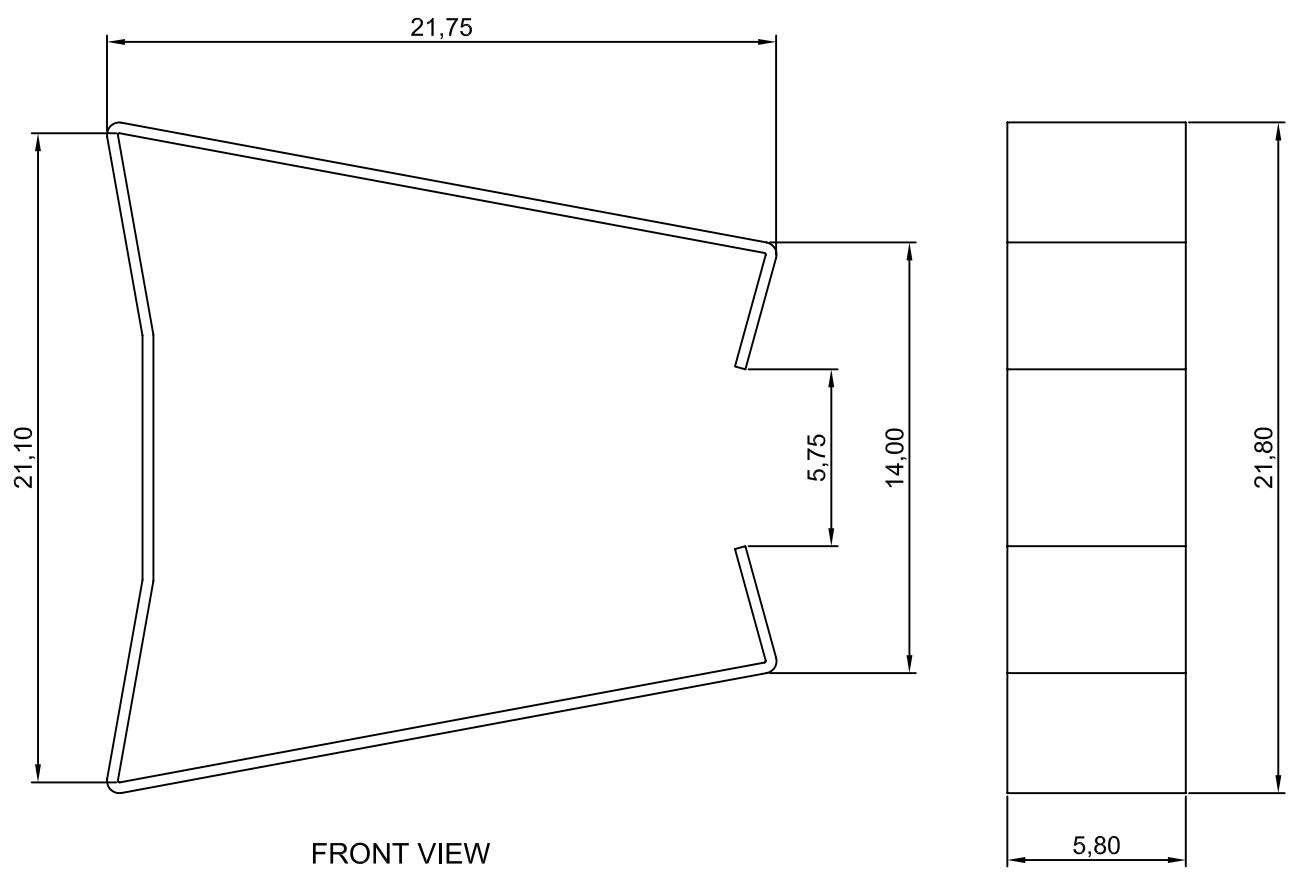

FRONT VIEW

R.H.SIDE VIEW

SHEET THICKNESS 0.35mm

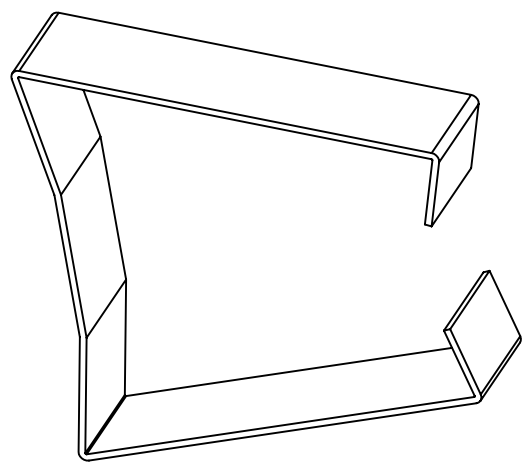

COMPONENT WEIGHT - 1.0 GMS

NOTE:
 (1) All dimensions are in mm.
 (2) Do not scale the drawing.
 (3) Tolerance for all dimension is (±0.2)
 (4) Material: Stainless Spring Steel



COMPONENT NAME: **CLAMP**

PART NO: **EE 2006**

	NAME	SIGN.	DATE	REMARKS:	REV.
DESIGN BY	SACHIDANAND	<i>Sachidanand</i>	09.08.05		00
CHECKED BY	MANOJ GUPTA		09.08.05		
APPR. BY	MANOJ GUPTA		09.08.05		
SCALE: NTS		DRG.NO: DEI/DRG/0222		PATH	