

SEC. A-A

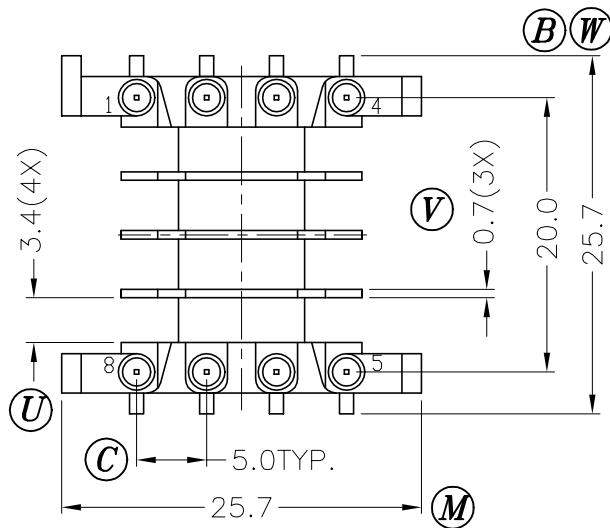

DRAWING NO.	MATERIAL:	ORIGIN:
P-2505-1	PET FR530	DG SZ

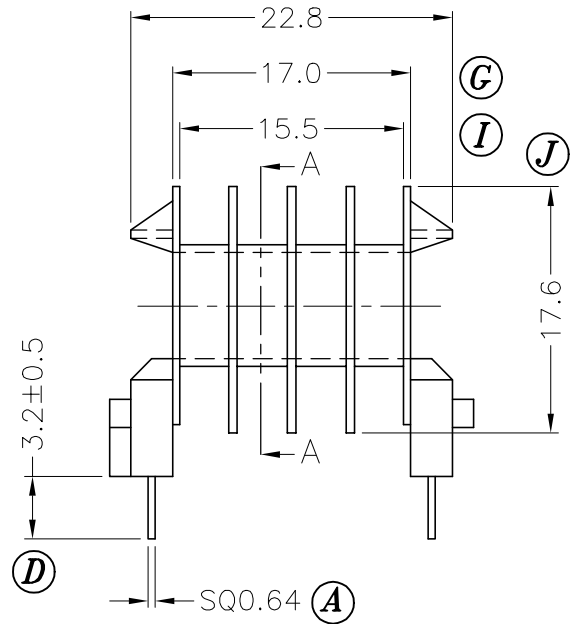
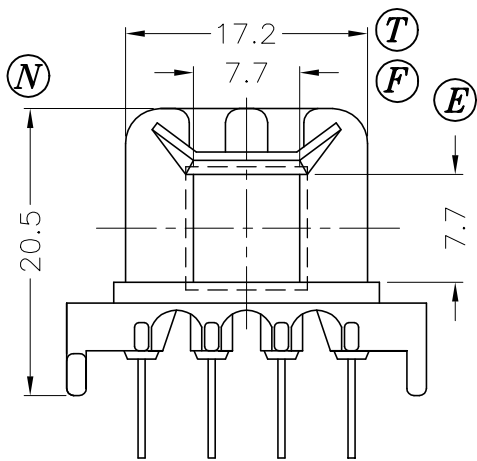
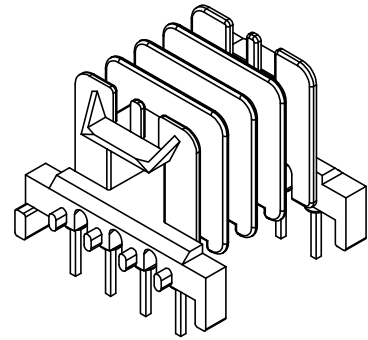
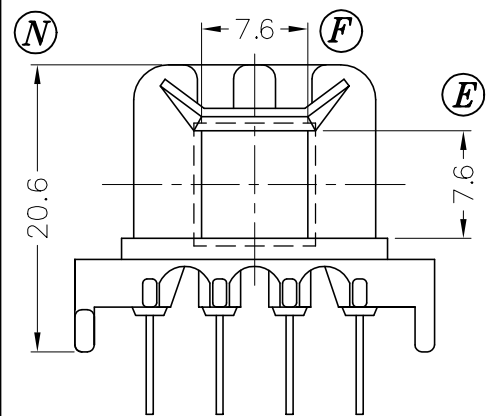

REV.	REVISIONS	REC.	REV.	REVISIONS	REC.
1	(L):20.6->20.5 (H1)8.9->9.0 (H):8.8->9.0				
2	(E): 7.6->7.7 (F): 7.6->7.7 (S): 8.4->8.1 (I1):3.3->3.4				
3	CANCEL (R),(S),(X),(P),(Q); UPDATE DRAWING				

DRAWN & DRAFTED BY WNCH HSIANG	TOLERANCES		ANGLE:	TITLE:			
	0<L≤4 ±0.1	pin pitch ±0.2	±1°	T-H BOBBIN EF-25H (4 SEC)			
CHECKED & APPROVED BY CHIN TE	4<L≤16 ±0.2		UNIT:	BOBBIN MATERIAL:	UL REC.		
	16<L≤63 ±0.3	MM	PET FR530	UL 94V-0			
 PIN SHINE INDUSTRIAL CO., LTD. TEL:886-2-22990545 FAX:886-2-22990546	ORIGIN:	DG	PIN MATERIAL:	CP WIRE	PIN TENSION LOAD: 1.5KG MIN		
			DATE:	APR.07 '2003	DRAWING NO.	P-2505	REV.